

OPTIONS
continued from page 3

Loose fill insulation

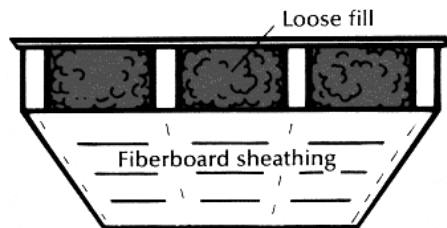

Any type of loose fill insulation can be installed under floors using fiberboard sheathing attached to the bottom of the joists every 6 inches with stainless steel staples. Insulation can then be blown in over the sheathing.

Staple the sheathing onto the



bottom of the joists every 6 inches. Fit each successive board closely up against the last one.

Cut a small hole in the sheathing inside each joist space to blow in



insulation. Tape the sheathing back over the hole when finished.

If your crawlspace has an access door opening into the home, it should be insulated to the same R-value as the rest of the under-floor. Staple R-19 batts onto the crawlspace side with the vapor barrier toward the house. The access door should be weather-stripped with self-adhesive foam rubber.

Feedback

If you have any questions on this issue or related crawl space or code questions, contact:

Evan Brown
Buildings & Programs Coordinator
Arkansas Energy Office
One Capitol Mall
Little Rock, AR 72201
(501) 682-7396
ebrown@1800arkansas.com

Information for this newsletter came from an article in Energy Source Builder issue no. 38, April 1995 - "Filling a Floor with Batt Insulation." The copyrighted material is reprinted with permission from Iris Communications (www.oikos.com).

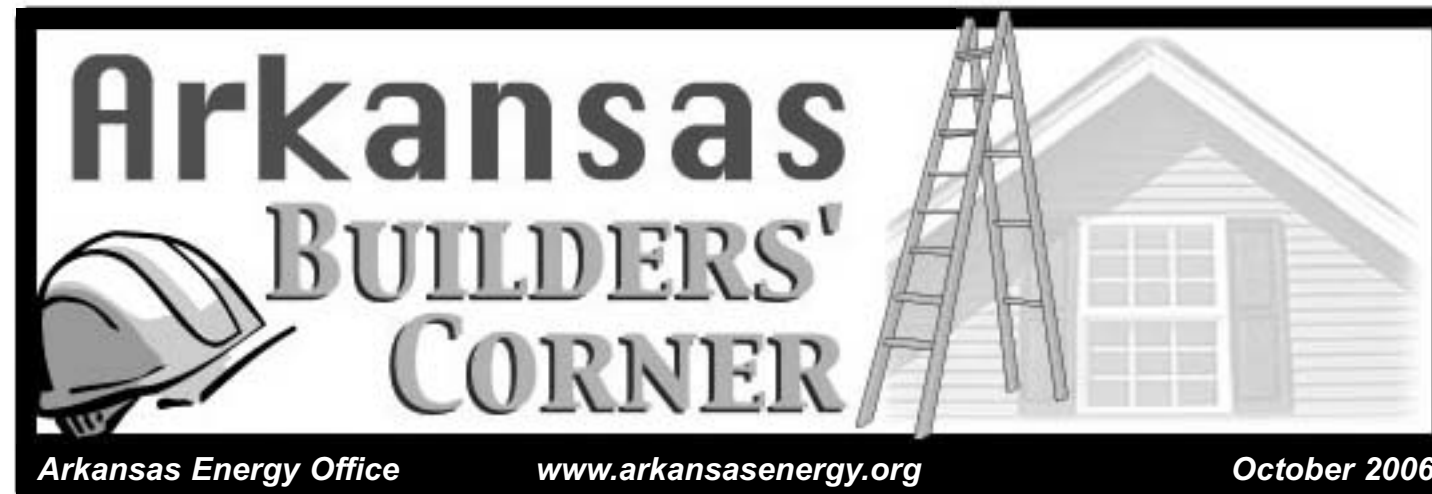

**From the ground up:
The crawlspace floor**

Why floor insulation works

Heat doesn't rise — it's hot air that rises. The myth that heat rises has been used to justify not insulating floors at all. This led to significant energy loss and very cold feet. An uninsulated floor will allow heat to move from the warm inside of the home into the cold crawlspace, causing the air on the floor to be cool. The warmer house air will rise causing it to stratify on the ceiling with cold air on the floor.

Heat can be lost in three ways and floor insulation reduces all three: convection (heat lost from air movement), conduction (heat transfer by contact) and radiation (transfer of heat due to a temperature difference). Insulating the floor slows down this heat loss and will make the home more comfortable. Floor insulation can also reduce heating costs by an estimated 57 percent (based on homes in Little Rock, in colder areas of the state the savings will be greater).

Moisture in the crawl space

Moisture travels upward through silt and clay soil. As much as 14 to 18 gallons per day have been noted under a 1,000-square-foot house — and this moisture evaporates within the crawl space. Even if the floor of a crawl space looks dry, it is still capable of wicking (like a wick in a kerosene lamp) a lot of water vapor into the crawl space and this can cause problems.

Controlling moisture

Leave foundation vents fully open year round unless they must be closed in winter to prevent frozen water pipes. A better solution is to insulate all exposed water pipes to prevent freezing.

The net free area of ventilation openings should not be less than 1 square foot for each 150 square feet of crawl space area. However, ventilation openings may be reduced to

*Steps for a
Better Floor*

Many newly constructed homes have an uninsulated wood floor over a crawlspace. There are three important items to be aware of when insulating a wood floor:

1) A **six-mil or thicker vapor barrier** or "retarder" needs to **completely** cover the ground. Although the ground might appear to be dry, there is still a necessity to carefully install the vapor barrier to keep the moisture out of the crawlspace.

2) While floor insulation is not "required" to pass the energy code (it's possible to "trade-off" the lack of floor insulation with higher levels of insulation; fewer and more efficient windows; or high efficiency heating and cooling systems), there is little possibility of a home passing the energy code without floor insulation. **R-19 is recommended under the floor in all parts of Arkansas.** This typical practice does have a few problems—the biggest one is that darn gravity. There are a variety of options for securing insulation to this envelope component.

3) The Arkansas Mechanical Code and the International Building Code both indicate that **all crawlspaces (and attics) require either natural or mechanical ventilation.**

Presorted
Standard
U.S. Postage
PAID
Little Rock AR
Permit 2987

ARKANSAS ENERGY OFFICE
One Capitol Mall / Little Rock, AR 72201
1-800-558-2633 / www.arkansasenergy.org



Constructing an effective ground cover

Constructing a good vapor barrier (or "retarder" as it is commonly called because it is almost impossible to construct a perfect barrier) takes more than throwing down a few pieces of poly and holding them down with bricks. The poly must be strong, carefully applied and sealed with an appropriate tape. Also, it is a myth that floors will buckle if the ground cover is complete. This might apply to an older home that has had a severe water problem in the crawl space. However, this circumstance does not apply to new construction. Before starting, clear the crawl space floor of any debris which might puncture or tear the ground cover.

The Poly: 6-mil polyethylene is typically used to cover the ground. While this is readily available and relatively cheap, it does not hold up well. There is wear and tear down there whenever anyone crawls over the surface, and punctures are bound to happen. Some wood flooring manufacturers are now recommending 8-mil poly instead of 6-mil.

Use 6- or 8-mil black reinforced polyethylene. Black polyethylene works better than clear, because the black plastic slows the growth of plants, which can occur even in a relatively dark crawl space. Clear many times will sweat, creating an additional moisture concern. There are a variety of reinforced polyethylene products on the market and they typically

have some visible strands embedded in the poly. This adds strength and reduces punctures. Overlap seams a minimum of 1 to 2 feet, wipe the poly clean and seal with good quality tape.

Protect the vapor barrier. Even a perfectly constructed vapor barrier can be punctured by someone crawling on it. There are a variety of techniques that are used to protect the vapor barrier from being damaged. Cover the polyethylene with a thin layer of sand or concrete to protect it from damage. Don't cover plastic with anything that could make holes in it, such as crushed gravel.

The Edge: The top edge of the polyethylene film needs to be bonded to the sheathing to form a seal. Extend the outside edge of the poly up the foundation wall to a point at least 6 inches above the outside grade. Seal the poly to the foundation wall by using construction adhesive, duct mastic/sealer or a pressure treated nailing strip.

The Tape: Not too many tapes can provide a permanent adhesion—polyethylene is made to be slippery and many tapes will not stay stuck to it. Even with the best of tapes, the poly needs to be wiped clean before taping. One tape that appears to work is available from an Arkansas business, the Darragh Company. "Vapor Bond" is an "aggressive" tape that comes in a 4-inch-by-210-foot-long roll and is made by Raven Industries.

The Ducts: All ducts should be

sealed with mastic or mastic tape and insulated with a vapor barrier. If the ducts are in the crawlspace, insulate them with four inch thick (R-11) insulation to keep them from sweating. Code only requires R-8.

Air Sealing: Before insulating the floor, make sure that all penetrations have been air-sealed. Foam all holes in the floor that were made for plumbing, electrical and ductwork (supply and return). When under the floor, use a can of foam to seal up the remaining areas that show up when light is visible passing through the un-sealed holes.

The Insulation: To reduce problems, insulate the floor first and then install the vapor barrier. If fibrous batt insulation is being used, consider purchasing unfaced batts. The slightly wider cut allows for a tighter fit. If faced batts have been purchased, the proper procedure is to place the faced part of the batt up towards the floor.

Crawl space grading

- The crawl space should preferably be higher than outside surface grade.
- Maintain an 18-inch minimum clearance from the bottom of joists to the soil surface, preferably 2 to 3 feet.
- The outside surface should grade away from the foundation at a minimum of 6 inches for the first 10 feet.
- Vent wells should be used if foundation vents are partially or fully below exterior grade.

each corner of the building.

Vents should not be obstructed by duct work, items stored in the crawl space or landscape plants.

Cover the crawl space with 6 mil polyethylene to keep soil moisture from vaporizing and reaching the wood substructure.

MOISTURE

continued from page 1

1/1,500 of under-floor area where the ground surface is treated with a carefully installed vapor barrier with one ventilation opening within 3 feet of

Options to secure underfloor insulation

Avoid the two most common flaws in floor insulation:

- 1) an air gap between the floor and the insulation (the insulation should be in contact with the floor above it), and
- 2) compression.

Since batts are made in a factory and floors are not, sometimes the floor joists are not consistently spaced. Cut the insulation to fit snugly without bunching between the floor joists.

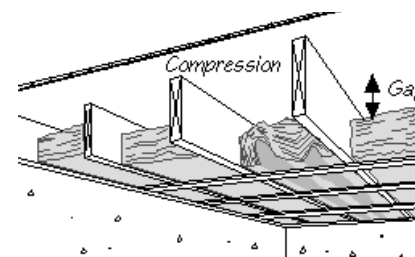

Two common flaws in floor insulation are gaps above the batt and compression of the batt in the cavity.

Gravity is a major factor that causes many floor insulation failures. The sharpened metal wires (called "tiger teeth" or "lightning rods") have not been found to be dependable (the points on each end of the hangers must penetrate the joists by at least 3/4 inch). These might hold the insulation up for a while, then they fail and the insulation falls to the ground. This quick and inexpensive option also compresses the insulation which reduces its effectiveness.

Batt insulation can be supported either with wire, chicken wire, nylon twine laced between the floor joists or with wood lath nailed or stapled into place. To be most effective the insulation needs to be in contact with the subfloor.

Push the insulation into place over the supports (chicken wire,

twine, wire, or wood lath) with the vapor barrier facing away from you, against the subfloor as shown in the following figures. Do not compress the insulation at any point, or you will lessen its insulating ability. Fit batts securely against each other. Repeat the process until the entire floor is insulated.

Following are several options to snugly hold floor insulation in place without compressing it.

Chicken wire

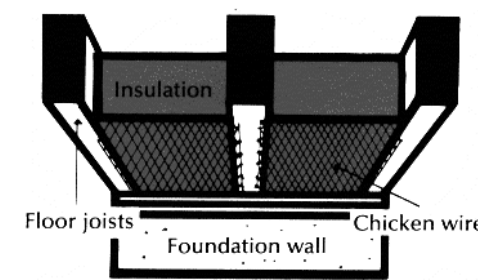

Nail or staple chicken wire onto the joist. Work with one width at a time, nailing into place every 12 inches.

Nylon twine

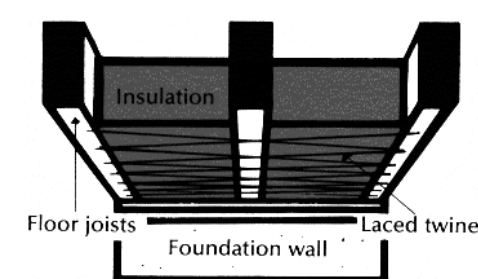

Staple nylon twine to joists every 12 inches and lace into a "shoelace" pattern. Use sturdy (150 pound breaking point) polypropylene twine.

Wire

Attach wire with staples or nails every 12 inches and lace in a

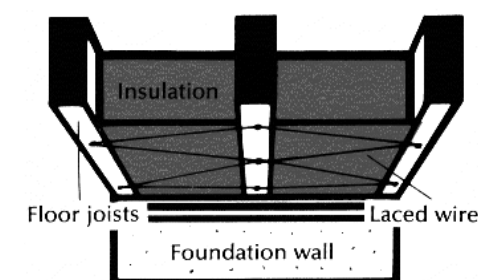

zigzag pattern. Use solid stainless steel or copper 18-gauge wire.

Wood lath

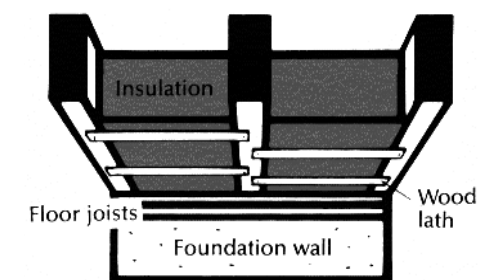

Nail or staple wood lath to the bottoms of beams or joists every 12 to 18 inches.

Plastic straps

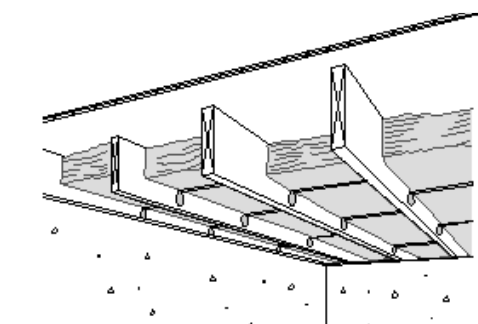

This method requires a product called Insul-Strap. It's a thin strap made of recycled plastic. The ends are wider for easy stapling. The strap can attach to the joist bottom or lift a batt up into the cavity without compressing it.

See **OPTIONS**, Page 4